

## A Holistic Approach to a New Superstore Environment for the Next Millennium

Doug King BSc, ARCS, CPhys, CEng, MInstP, MInstE

Capita Greatorex, Salter House, 263-265 High Street, Berkhamsted, Hertfordshire, HP4 1AB

A concept design is proposed for a new generation of superstores, which addresses the global problem of Carbon Dioxide emissions and the demand of retail traders for increasing economies in energy. The new superstore building has been engineered from the ground up to incorporate the current best practice in environmental design. With application of suitable energy conservation technologies it is proposed that this approach will provide a retail environment fit for the next millennium and achieve a 50% reduction in Carbon Dioxide emissions over a conventional supermarket. The new superstore is designed to achieve an excellent rating for Carbon Dioxide reduction measures under the BREEAM environmental assessment method.

### Introduction

Energy consumption in buildings is responsible for the emission of some 280 million tonnes<sup>(1)</sup> of atmospheric Carbon Dioxide annually, nearly half of the total emissions from the UK. The Government has declared a target to reduce Carbon Dioxide emissions to 20% below 1990 levels by the year 2010. Clearly the design of new buildings commissioned within the next decade can make a significant contribution to this target reduction.

Retail superstores with their high electrical demands for lighting, refrigeration, air-conditioning etc. can be seen to be major contributors to Carbon Dioxide emissions. For sound commercial reasons many UK retailers are adopting energy efficiency policies. However these rely largely upon technology to monitor and improve the efficiency of energy consuming systems. In order to make a quantum leap in energy conservation a fundamental change in the traditional design of the superstore environment needs to take place.

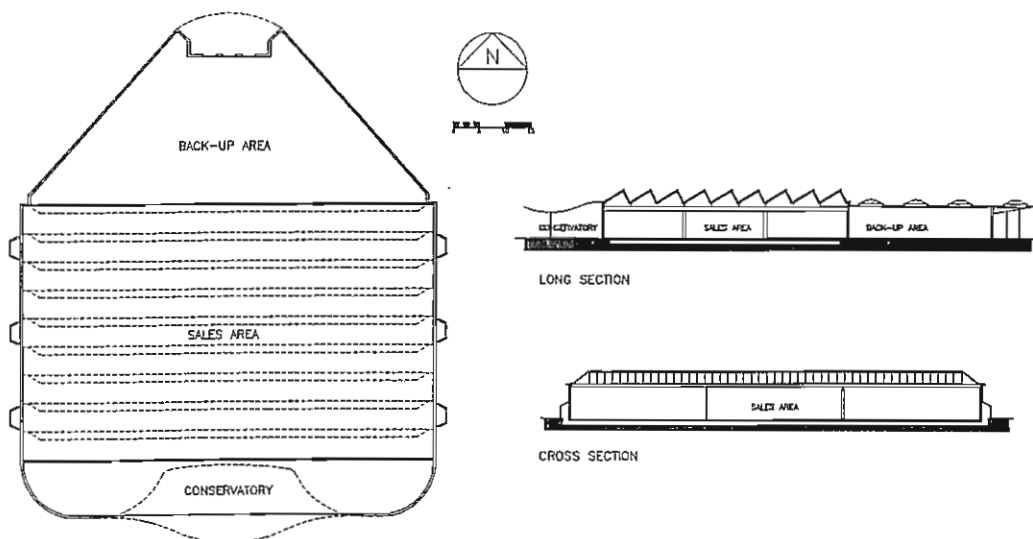

Figure 1: The new concept superstore

The new superstore has been re-engineered from the ground up to incorporate the best practice in environmental design presently applied in other building types. This building has turned the conventional supermarket design on it's head, providing space conditioning from below, to allow removal of the suspended ceiling for effective daylighting. The building form and servicing requirements have been carefully examined for their interactions and wherever possible each component of the building has been optimised to provide multiple functionality within the whole.

**A New Approach**

In retail buildings the space conditioning has traditionally been provided by ventilation supply air in order to maximise the retail floor area. Adherence to this approach has led to a number of in-built inefficiencies and has restricted the potential for development of new environmental servicing strategies such as those now being proven in office buildings.

In winter to achieve the radiant heat component essential for comfort, the bulk air temperature must be raised significantly. In order to drive warm air to floor level relatively high velocities are required and the resulting turbulence can disturb the cold air in the refrigeration cabinets raising both the heating requirement for the space and the refrigeration load. In summer, cool supply air must first mix with hot stratified air beneath the ceiling before it can reach the occupied zone. The need for suspended ceilings to support and conceal the air-conditioning system prevents the effective introduction of daylight into the space.

Reversing this arrangement and providing the heating and ventilation directly to the occupied zone results in a system that is much more responsive to small changes, allowing the overall energy input to be significantly reduced. The new store has a mixed mode natural ventilation solution using under floor supply with floor slab heating and cooling to control the comfort conditions, the heat being recovered from produce refrigeration. The removal of suspended ceilings allows for effective daylighting of the sales floor using rooflights, which in turn can be opened to exhaust vitiated air and excess heat.

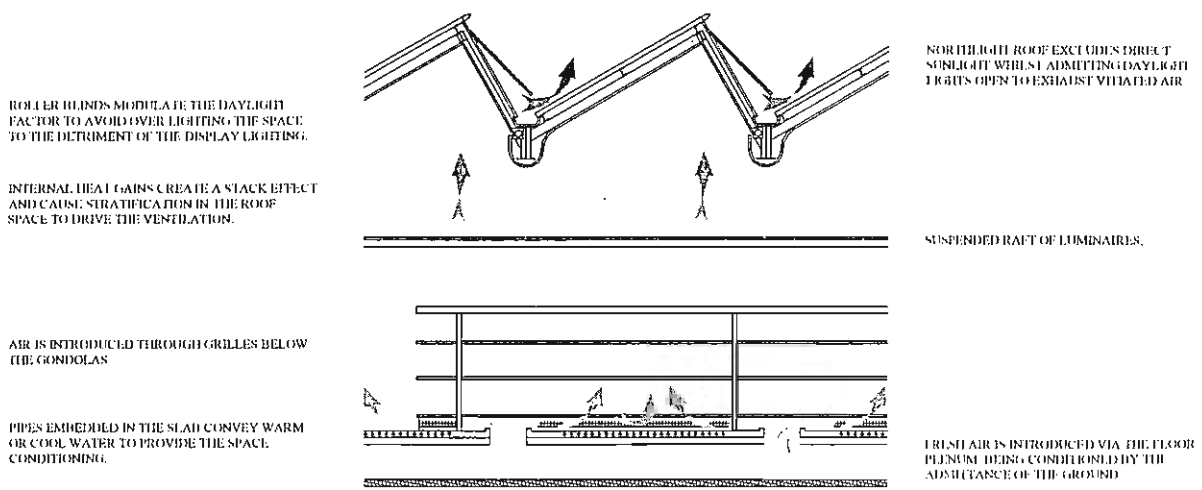

*Figure 2: Section through proposed store*

Similar principles are also applied to the back of house areas although these are not examined in this paper. A few areas of conventional mechanical servicing remain, such as kitchens, fish counter, bakery, etc. where a natural ventilation strategy would not be appropriate.

### Thermal Environment

The building will have insulation values significantly better than those presently required under the building regulations. The target is to achieve a U value of  $0.2 \text{ W/m}^2\text{K}$  for the roof, the major element of the envelope. Careful detailing of the building envelope ensures that unwanted air paths are sealed, reducing the heat loss through uncontrolled ventilation. The rooflights are double glazed with low E, solar control glass.

Water pipework is incorporated into the construction of the floor slab as in a conventional floor heating system. During the heating season warm water for heating is derived from the refrigeration plant. In summertime circulation of cooling water through the floor slab will provide radiant cooling to control internal temperature rises in conjunction with the displacement ventilation.

There will always be a net heat flow out of the internal space as long as refrigeration for produce is required. Even during the hottest days there will be a requirement for some heating to replace that extracted by the refrigerated cabinets. Dividing the slab into a number of zones allows heat to be returned to the aisles with refrigeration cabinets throughout the year even when the remainder of the building is provided with cooling thus producing more equitable conditions throughout the store.

### Ventilation

The sales floor will be ventilated by a displacement system. This will utilise the additional height gained by the omission of the suspended ceiling to allow stratification to take place. Hot air will be exhausted from the stratification reservoir via the rooflights.

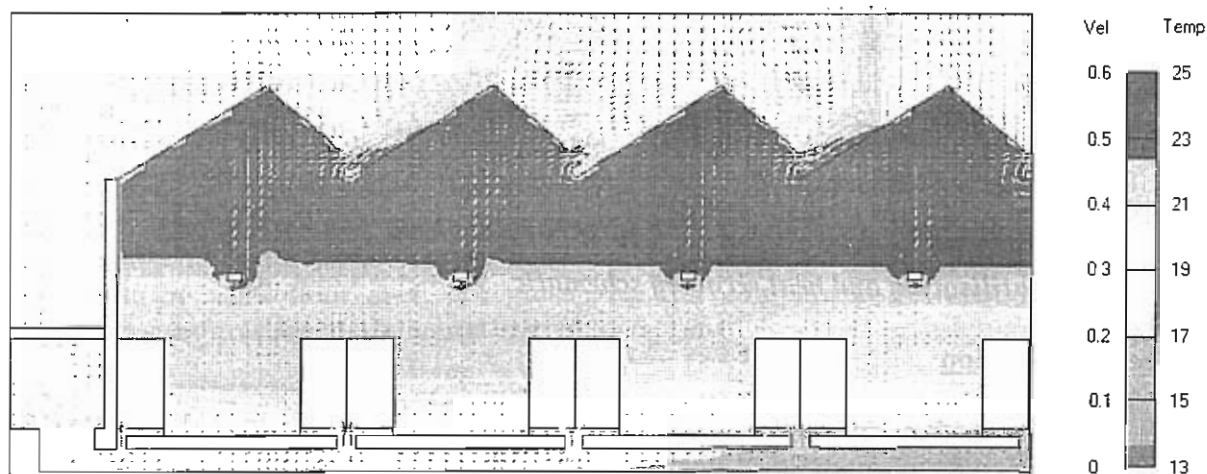

*Figure 3: CFD prediction of airflow & temperatures in the superstore*

Air is introduced via an underfloor plenum through grilles at low level in the gondolas. The supply air is tempered by the admittance of the ground and of the suspended floor slab. A similar underfloor ventilation system has achieved supply air temperatures  $3 \text{ }^\circ\text{C}$  below ambient in summer<sup>(2)</sup>. Throughout much of the year sufficient convection is generated within the store to drive the ventilation by stack effect and maintain the design fresh air ventilation rate. During the summer on warm still days or when higher ventilation rates are required fans located in the inlet terminals assist the system. As the system resistance is low fan power requirements are greatly reduced.

## Water Resources

In the United Kingdom sources of water in the environment are widely available, either as watercourses or groundwater close to the surface. In a few instances it may be necessary to sink boreholes into deep aquifers to obtain groundwater. For the new store a number of boreholes will be sunk to provide a source of high quality ground water. This water will be utilised to meet the non-domestic requirements of the building: waste disposal, non-domestic cleaning, irrigation etc.

A further benefit of ground water is that at depth the ground temperature is virtually constant through out the year at approximately 10 °C to 12 °C. This will be used as the primary source of cooling for the building. At these temperatures beneficial cooling will be obtained by circulating the water through the embedded floor coils. This cooling source will also be used to cool the refrigeration plant with warm water being returned to the store or rejected to the ground via soakaways.

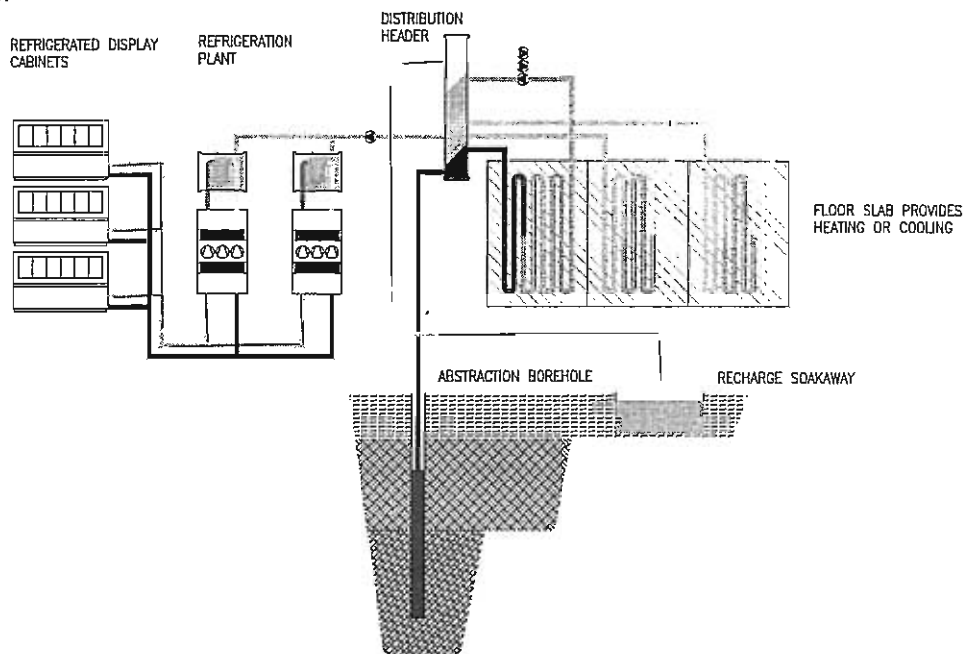

*Figure 4: Water utilisation and heat recovery schematic*

## Produce Refrigeration

The largest energy consumer in the store is refrigeration for produce. In order to keep the produce cool a significant quantity of heat is removed from the environment inside the store. Incorporation of night blinds and modifications to refrigeration cabinets described by Palmer<sup>(3)</sup> are well proven to reduce the refrigeration load by improving the containment of cold air. However any further improvements in the system efficiency need also to address the refrigeration process.

Heat from refrigeration is typically rejected to atmosphere at a temperature of 40 °C to 45 °C in order to overcome summertime air temperatures. The refrigeration process therefore is inefficient, as the heat has to be removed across a large temperature differential. Heat recovery to ventilation air is also inefficient as the temperature is rather too low for efficient heating and additional fan power is required to drive air through the heat exchange coils.

The refrigeration for the new store utilises water cooled condensers operating with water drawn from the boreholes and introduced to the condensers at about 15 °C, significantly reducing the temperature gradient. When there is a requirement for space heating in the building the refrigeration plant is controlled to provide water off temperatures of about 30 °C and the warm water is circulated through the floor slab coils.

During the summer the cooling water is circulated through the floor coils before being supplied to the condensers to achieve free comfort cooling to the store.

### Lighting

Conventionally, lighting in retail stores has simply followed the principles of office lighting in specifying illuminance levels on the horizontal plane. Reflection is then relied on to illuminate the product on the vertical plane resulting in much higher levels of illumination than strictly necessary. The general level of illumination is about 1000 lux. In addition, certain food display cabinets are illuminated to a higher lighting level, about 2000 lux in order to provide the necessary emphasis. With the extended opening hours now typical in superstores the benefit of reducing the hours of lighting use is significant.

The design of the new store incorporates north facing rooflights to provide a 20% daylight factor. Translucent, motorised blinds across the rooflights can be modulated to control excessive daylight. A conventional ambient lighting system is provided and includes daylight linking controls to utilise the benefit of daylight. The accent lighting becomes localised to the product displays and is arranged to provide illuminance on the vertical plane. Once again daylight linking controls will allow use to be made of daylight when available. During non-trading hours the lighting will be reduced to the ambient level. At night for cleaning and restocking activities the lighting will be controlled aisle by aisle on presence detection for further savings.

### Energy Consumption Prediction

The following calculations assume a working year of 5400 equivalent hours full operation. This is based on general operation of 07:00 hrs to 22:00 hrs with trading 08:30 hrs to 20:00 hrs for 6 days per week with some 7<sup>th</sup> day trading and intermittent overnight restocking periods. The energy consumption calculations are based on a store with 3500 m<sup>2</sup> sales. The figures are normalised by sales floor area, not gross area, for comparison between retailers. Energy consumption figures are for delivered energy.

	Proportion of total	Electricity kWh/m <sup>2</sup>	Gas kWh/m <sup>2</sup>	CO <sub>2</sub> emission kg/m <sup>2</sup>
Refrigeration	47%	582	-	303
HVAC	20%	100	148	82
Lighting	18%	223	-	116
Bakery	8%	99	-	51
Other	7%	83	4	44
<b>Totals</b>		<b>1087</b>	<b>152</b>	<b>596</b>

*Table 1: Typical annual energy consumption for a superstore* <sup>(4)</sup> <sup>(5)</sup>

1. Refrigeration systems operate with a coefficient of performance (COP) proportional to the temperature gradient over which heat must be rejected. Food refrigeration temperatures range from 4 °C to -20 °C. Assuming an average refrigeration temperature of -4 °C, condensing at 20 °C,

using borehole water, would provide a theoretical doubling in COP over condensing at 40 °C as in most conventional systems. However, due to system losses etc. it is not anticipated that the full increase in COP can be realised and the overall system improvement is estimated at 40%.

2. Space heating is provided from occupancy gains and heat recovery from refrigeration and therefore no additional energy input is required.

3. Cooling is obtained from groundwater for free as an incidental benefit of using water cooling for the refrigeration.

4. The displacement ventilation requires a driving pressure of about 2.5 Pa. This is driven by stack effect when the external temperature is below 20 °C. It is estimated that the fans will be required to run for about 800 hours per year when the temperature exceeds 20 °C during the working day<sup>(6)</sup>. The electrical power for the displacement ventilation is about 3 kW, equivalent to 1 kWh/m<sup>2</sup>/year. The major remaining loads in the ventilation system will be the mechanical extracts from the bakery, fish counter and restaurant areas at 8 kWh/m<sup>2</sup>/year.

5. During the working year daylight is available for 3500 hours at 5 klux or higher and 2500 hours at 10 klux or higher<sup>(7)</sup>. With rooflighting to give a daylight factor of 20% this will provide 1000 lux and 2000 lux respectively on the sales floor. Thus daylight is available to provide the ambient lighting for 65% of the year. Furthermore the higher lighting level is available from daylight for 45% of the year. Assuming suitable lighting control then the availability of daylight provides a potential saving of 60%.

	Proposed reduction	Electricity kWh/m <sup>2</sup>	Gas kWh/m <sup>2</sup>	CO <sub>2</sub> emission kg/m <sup>2</sup>
Refrigeration	40%	349	-	181
Heating	100%	-	-	0
Cooling	100%	-	-	0
Ventilation	91%	9	-	5
Lighting	60%	89	-	46
Bakery	0%	-	99	21
Other	0%	83	4	44
<b>Totals</b>		<b>530</b>	<b>103</b>	<b>296</b>

Table 2: Proposed annual energy consumption for the environmental superstore

### Capital Cost & Payback

The following cost estimate has been prepared from comparison of the new design with a conventional model supermarket<sup>(8)</sup>. Variations from the model have been priced from published price data<sup>(9)</sup>. The cost of energy to the retailer is assumed to be 4.57 p/kWh for electricity and 1.1 p/kWh for gas<sup>(5)</sup>. Once again the figures relate to the sales floor area.

Annual saving in energy cost (difference in table 1 & table 2 above):

Electricity 557 kWh/m<sup>2</sup> year @ 4.57 p/kWh = £25.455/m<sup>2</sup>

Gas 49 kWh/m<sup>2</sup> year @ 1.1 p/kWh = £ 0.539/m<sup>2</sup>

**Total annual saving = £25.994 / m<sup>2</sup>**

CIBSE NATIONAL CONFERENCE 1998

Element	Conventional Store	Environment Store	Extra Over Cost
Floorslab	Ground beam & pad foundations, insitu slab on hardcore, service ducts etc.	Ground beam & pad foundations, suspended slab over 700mm undercroft, pebblebed or hardcore	£27/m <sup>2</sup>
Roof	Membrane & insulation on steel deck. Natural slate edge treatment on felt & timber.	Insulated profiled metal roof. Double glazed, aluminium framed rooflights, 1/3 opening	£175/m <sup>2</sup>
Ceilings	Suspended metal panel ceiling .	Metal Panel lining to roof frame.	Nil
HVAC	Air-conditioning plant & ductwork, gas fired heating, chillers, controls insulation & commissioning.	Mixed mode natural ventilation, fan assistance, louvres etc. floor heating system, boreholes.	( £80/m <sup>2</sup> )
Lighting control	None	Daylight linked dimming controls, automatic blinds to rooflights.	£35/m <sup>2</sup>
Refrigeration	Refrigerated display cabinets, central compressor plant, forced air condensers.	Refrigerated display cabinets, central compressor plant, water jacket condensers.	Nil
<b>Total</b>			<b>£157/m<sup>2</sup></b>

*Table 3: Comparison of construction methods and costs.*

Thus, assuming a discount rate of 6%, the annual energy cost saving of £25.994/m<sup>2</sup> will achieve payback on the additional capital investment of £157/m<sup>2</sup> in 7.25 years. It should be noted that this payback calculation does not take into account the additional savings to be made through reduced plant maintenance requirements which would shorten the payback period.

### Conclusion

It can be seen from the proposals outlined here that the energy economy potential in superstores is not merely limited to improvements on existing systems. Few of the technologies proposed in this paper are entirely novel, having been proven individually in other applications. However it is the holistic approach to the building design that achieves the significant advance of combining these diverse technologies into a unified whole.

The costs associated with implementing these measures are significant but, with a potential saving of over £25/m<sup>2</sup> each year in fuel costs alone, the payback period is short enough to merit serious consideration. The future benefits to the superstore retailer will of course be significantly reduced operating and maintenance costs which, given the competitiveness of the sector will provide significant advantage.

Retailers can also play a unique role in promoting the public awareness of energy conservation. The retail superstore has a very high public profile and, with the high level of new store development, initiatives in design are very quickly adopted throughout the sector.

### Environmental Assessment

To attempt a full BREEAM<sup>(10)</sup> assessment is outside the scope of this paper, however the following salient points may be noted:

- The design proposed is capable of achieving 54 points (very good) for measures to reduce CO<sub>2</sub> emissions, even before the retailer has made decisions on the refrigeration cabinets and bakery equipment, putting an excellent or outstanding rating within easy reach.
- Credits are gained for the use of natural ventilation and the elimination of ozone depleting refrigerants from air conditioning. Additional credits could also be gained from the use of an HFC or preferably a hydrocarbon refrigerant such as Ammonia or Propane for produce, although these refrigerants require greater care in their application.
- The use of a sealed groundwater heat rejection system for the refrigeration will remove a potential environmental noise problem and any sources of Legionnaires' disease, both gaining further credits.

It must be acknowledged, however, that the construction of out of town superstores, for which this design is best suited, can in itself be a source of environmental damage. The environmental pollution caused as a result of journeys to the superstore must form a part of the overall environmental assessment. The debate regarding the provision of car parking spaces and petrol filling stations is yet to be had with most retailers and local authorities. Clearly the integration of such developments with public transport infrastructure is to be desired.

### Acknowledgements

The initial concept for the design behind this paper was developed for J Sainsbury Plc with Chetwood Associates, architects, whilst the Author was a partner of Max Fordham Associates. The Author also wishes to acknowledge the contribution of the following individuals to the continuing development of this concept:

Barrie Wilde, Robert Bohannon - BDP Lighting  
Nigel Howard - BRE, Centre for Sustainable Construction  
Paul Batty - Price & Myers, Structural Engineers

### References

1. Henderson G & Shorrock LD (1990) Greenhouse-gas Emissions and Buildings in the United Kingdom, Information Paper 2/90: BRE, Garston
2. Thomas R (1995) Environmental Design, *Case Study: RMC International Headquarters*: E&FN Spon, London
3. Palmer G (1997) Cool Running: *Building Services Journal* Vol 19, Issue 10
4. Anon (1996) Energy Efficiency, Environmental Best Practice Guide: J Sainsbury PLC, London
5. J Sainsbury Plc (1997) Private Communication.
6. Anon (1986) Weather and Solar Data, CIBSE Guide A2: CIBSE, London
7. Hunt DRG (1979) Availability of Daylight, Report 21: BRE, Garston
8. Davis Langdon & Everest (1993) Cost Check: Supermarkets: *Building*, 16 April 1993
9. Davis Langdon & Everest (1998) Spon's Architects' and Builders' Price Book: E&FN Spon, London
10. Crisp VHC, Doggart J & Attenborough M (1991) An Environmental Assessment Method For New Superstores And Supermarkets, BREEAM 2/91: BRE, Garston.